



Serie ENERGY 75-85

2850 l/min 50 Hz.

Mandata 2"

Data 01/05/19
Mod. E



Per drenaggio di liquidi anche luridi con corpi solidi o filamentososi in sospensione, **con girante vortex**.

For draining dirty liquids and sewage with suspended solid or fibrous materials, vortex impeller.



ITA

Caratteristiche ed impieghi

Elettropompa sommergibile portatile per impieghi universali.

Ideale per il drenaggio di liquidi anche luridi con corpi solidi o filamentososi in sospensione, prosciugamento di scavi e terreni acquitrinosi, svuotamento di pozzetti e fosse nere, smaltimento acque usate domestiche e industriali.

Questa elettropompa viene fornita, su richiesta, completa di basamento per accoppiamento rapido.

Motore elettrico asincrono a gabbia di scoiattolo in bagno d'olio atossico, protezione IP 68, isolamento in classe F.

Versione monofase: 1,5 HP con motoprotettore e condensatore incorporati,

2 HP in un quadretto elettrico esterno.

Versione trifase: protezione a carico dell'utente.

Fusioni principali in GG 25, albero AISI 420, cavo neoprene H07RN8-F oil resistant, viteria AISI 304, O.Rings e tenuta a labbro in nitrile, tenuta meccanica in carburo di silicio + allumina.



ENERGY 85 MG



ENG

Features and used

Universal portable submersible electric motor pump.

Best uses for draining dirty liquids and sewage with suspended solid or fibrous materials, on construction sites and for dewatering floated fields, emptying out sump pits and septic tanks, for domestic and industrial waste water. On request, these pumps can be supplied with duct-foot pedestal for automatic coupling.

Motor asynchronous squirrel cage type in dielectric anti-oxide oil bath, protection degree IP 68 and insulation class F.

Single-phase feeding: 1,5 HP with incorporated motor protector and with built in capacitor; 2 HP with box control.

The three-phase feeding with compulsory protection to be provided by the user.

Motor housing Cast iron GG 25, shaft stainless steel AISI 420, electric cable neoprene H07RN8-F oil resistant, bolt A2 class AISI 304, O.ring and lip seal nitrile, mechanical seal on silicon carbide + allumina.

Limiti di impiego

Temperatura Max. del liquido pompato	40°C
Massima profondità di immersione	20 m
PH del liquido pompato	6 ÷ 10
Massima densità liquido pompato	1,1 Kg/dm ³
Tensione di alimentazione -Monofase 230V ±6% -Trifase 400V ±10%	
L'elettropompa genera un livello di pressione acustica inferiore a 70 dB	

Operating limits

Max. temperature of pumped fluid	40°C
Max. immersion depth	20 m
PH of pumped fluid	6 ÷ 10
Max. density of pumped fluid	1,1 Kg/dm ³
Net supply tensions -Single-phase 230V ±6% -Three-phase 400V ±10%	
The electric pump generates an acoustic pressure level of less than 70 dB	

Curva caratteristica - Performance curve

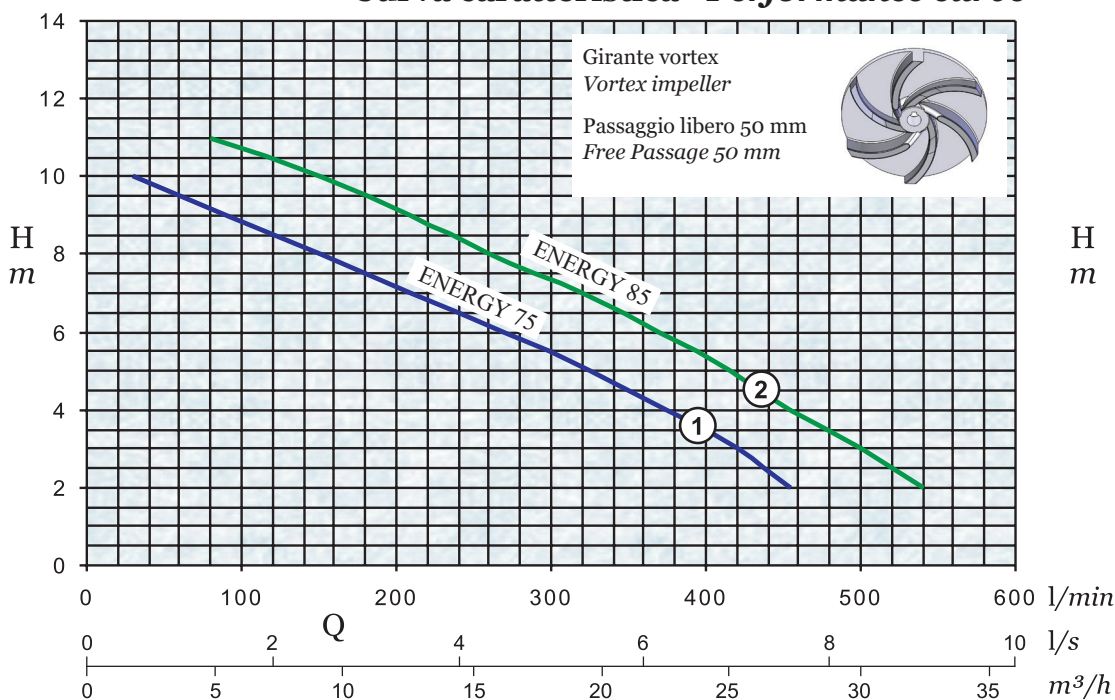

15		
14		
13		
12		
11		80
10	30	150
9	90	210
8	150	260
7	210	320
6	270	370
5	325	415
4	375	455
3	420	500
2	455	540
1	-	-
m	l/min	l/min
	①	②

Q = Portata - Capacity

H = Prevalenza - Head

Curve secondo UNI/ISO 9906 Livello 2
Performance as per UNI/ISO 9906 Grade 2

Dati tecnici - Technical data 50 Hz.

Curva Curve	Codice Code	Elettropompa Electric Pump	Galleggiante Float swicht	P2 HP kW	Volts	In A	μF	Poli Poles	l/min	Cavo Cable
①	ES.02.015	ENERGY 75 M	NO	1,5 1,1	1 ~ 230	8,4	30	2	2850	3 x 1 mm ² - 10 m
	ES.02.115	ENERGY 75 MG	SI ELET-MEC.							
	ES.02.023	ENERGY 75 T	NO							
	ES.02.073	ENERGY 75 TG	SI ELET-MEC.							
②	ES.02.016	ENERGY 85 M*	NO	2 1,5	1 ~ 230	9,4	40	2	2850	4 x 1 mm ² - 10 m
	ES.02.116	ENERGY 85 MG*	SI ELET-MEC.							
	ES.02.024	ENERGY 85 T	NO							
	ES.02.074	ENERGY 85 TG	SI ELET-MEC.							

1 ~ 230 Volts = Monofase / Single-phase - 3 ~ 400 Volts = Trifase / Three-phase

P₂ = Potenza resa dal motore / Power rated by the motor

ENERGY 85 M*/MG* = Condensatore e motoprotettore in pannello di controllo esterno/starting capacitor and motor protector in the external box control.

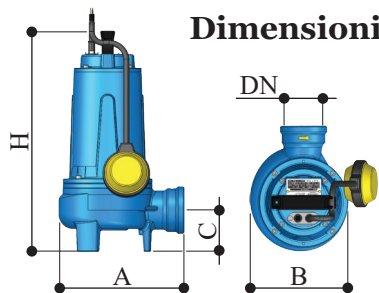

Dimensioni di ingombro e pesi - Overall dimensions and weights

Elettropompa Electric Pump	DN (inch)	H	A	B	C	H ₁	A ₁	B ₁	Kg.
ENERGY 75	2"	391	210	170	74	460	250	200	20
ENERGY 85									22

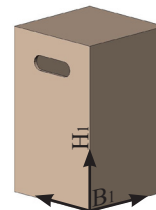

Costruzione - Construction

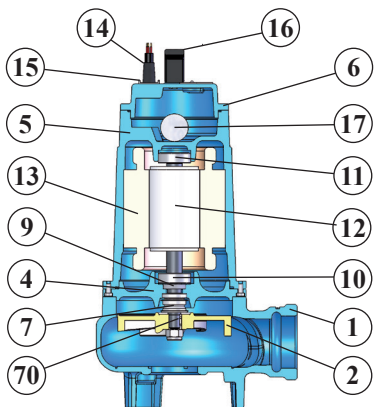

Pos.	Descrizione	Description
1	Corpo pompa GG 25	Pump body GG 25
2	Girante vortex GG 25	Vortex impeller GG 25
4	Flangia portacuscinetto GG 25	Flange intermedie GG 25
5	Cassa motore GG 25	Motor casing GG 25
6	Coperchio del motore GG 25	Cover for motor casing GG 25
7	Tenuta meccanica carburo di silicio + allumina	Mechanical seal on silicon carbide + allumina
9	Tenuta a labbro	Lip seal nitrile
10	Cuscinetto inferiore	Lower ball bearing
11	Cuscinetto superiore	Upper ball bearing
12	Albero motore AISI 420 + rotore	Rotor + shaft AISI 420
13	Statore	Stator
14	Passacavo NBR	Chock NBR
15	Pressacavo INOX 316	Cable entry nut INOX 316
16	Maniglia in nylon	Handle
17	Condensatore interno (solo 1,5 Hp in 1~230 Volts)	Capacitor inside (only 1,5 Hp on 1~230 Volts)
70	Linguetta	Key

Installazione immersa fissa con dispositivo di accoppiamento rapido codice **RS.28.003 (2")**
 Permanent submersible version with automatic coupling foot code **RS.28.003 (2")**

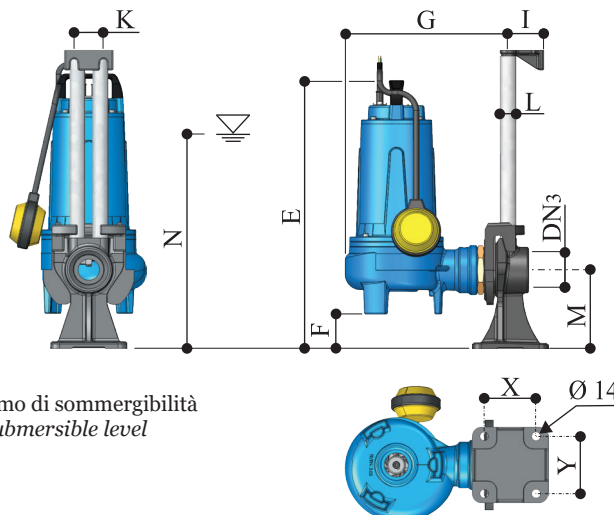
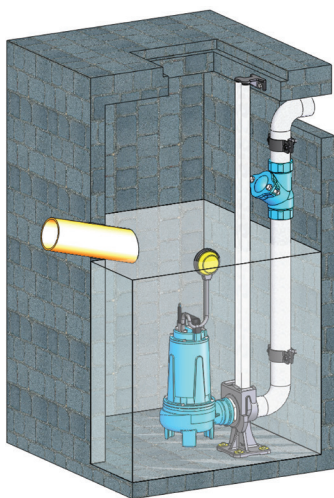

Livello minimo di sommersibilità
 Minimum submersible level

	mm
DN3	2"
E	447
F	56
G	252
I	59
K	37,5
L	3/4"
M	130
N	360
X	85
Y	94