



Serie QM 101 165 - 166

1450 l/min 50 Hz.

Mandata DN 100

Data 03/05/19
Mod. E



Le pompe ottimali per le acque reflue e gli impianti di depurazione, **con girante monocanale aperto.**

The ultimate pumps for waste water and purification equipment, with single channel opened impeller.



Caratteristiche ed impieghi

Le elettropompe sommergibili QM per la loro solida costruzione e grazie alla girante monocanale, caratterizzata da buona sicurezza contro l'intasamento, larghi passaggi sferici, buona resistenza all'usura, bassa azione meccanica sul fluido, elevato rendimento idraulico, sono particolarmente adatte per il sollevamento di acque chiare, acque cariche contenenti corpi solidi e fibrosi, acque cloacali, liquami e fanghi.

Sono previste sia per installazione fissa con dispositivo di accoppiamento rapido che installazione mobile con base di appoggio.

Motore elettrico asincrono 4 poli trifase a gabbia di scoiattolo in bagno d'olio atossico, protezione IP 68, isolamento in classe F. Fusioni principali in GG 25, albero AISI 420, cavo neoprene H07RN8-F con terminali liberi, viteria AISI 304, O.Rings in nitrile.

La tenuta sull'albero motore, a protezione del motore elettrico, viene garantita da due tenute meccaniche montate in serie in camera d'olio atossico. Tenuta lato motore ceramica/graffite mentre lato girante in carburo di silicio. Sensore di conduttività e sonde termiche a richiesta.



Features and used

Submersible electric pump QM, thanks to their tough construction and the single channel opened impeller, that offers reliability against clogging and features wide through sections and a good resistance to wear, low mechanical action on the fluid, high hydraulic efficiency, is particularly suitable for clean water, water containing solid and fibrous solids, cloacal water, sewage and sludge.

Is possible the submersible fixed installation with the automatic coupling foot or the mobile installation with base support.

Motor asynchronous 4 poles on three-phase squirrel cage type in dielectric anti-oxide oil bath, protectin degree IP 68 and insulation class F. Motor housing Cast iron GG 25, shaft stainless steel AISI 420, electric cable neoprene H07RN8-F with free therminals, bolt A2 class AISI 304, O.ring nitrile. Shaft sealing by two mechanical seals mounted in series in ecologic oil chamber. Seal types applied to the motor side on ceramic/graphite and seal types applied to the wet end side on silicon carbide.

Conductivity sensor and thermal probes on request.

Limiti di impiego

Temperatura Max. del liquido pompato	40°C
Massima profondità di immersione	20 m
PH del liquido pompato	6 ÷ 10
Massima densità liquido pompato	1,1 Kg/dm ³
Tensione di alimentazione: Trifase 400V ±10%	
L'elettropompa genera un livello di pressione acustica inferiore a 70 dB	

Operating limits

Max. temperature of pumped fluid	40°C
Max. immersion depth	20 m
PH of pumped fluid	6 ÷ 10
Max. density of pumped fluid	1,1 Kg/dm ³
Net supply tensions: Three-phase 400V ±10%	
The electric pump generates an acoustic pressure level of less than 70 dB	

Curva caratteristica - Performance curve

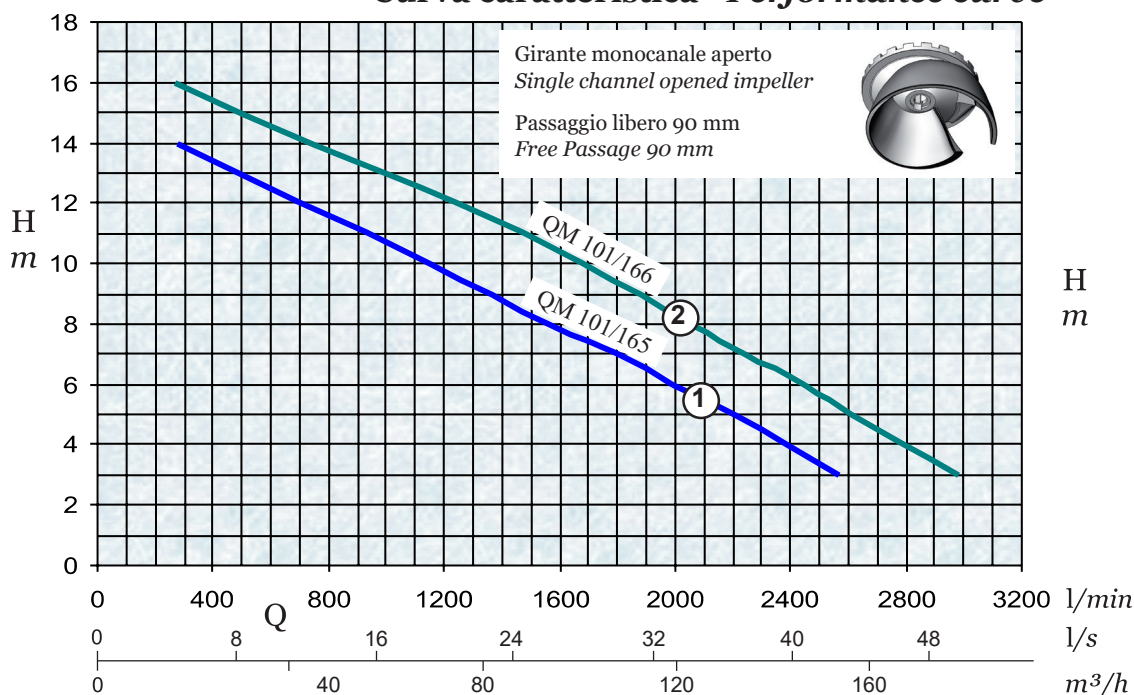

18		
16		270
14	280	740
12	700	1240
10	1150	1680
8	1560	2050
7	1800	2240
6	1990	2450
5	2200	2610
4	2380	2790
3	2570	2980
2	-	-
m	l/min	l/min
	①	②

Q= Portata - Capacity

H= Prevalenza - Head

Curve secondo UNI/ISO 9906 Livello 2
Performance as per UNI/ISO 9906 Grade 2

Dati tecnici - Technical data 50 Hz.

Curva Curve	Codice Code	Elettropompa Electric Pump	P2		Volts	In A	Poli Poles	l/min	Cavo Cable
			HP	kW					
①	ES.06.019	QM 101/165	5,5	4,1	3 ~ 400	9,4	4	1450	4 x 2,5 mm ² - 10 m
②	ES.06.021	QM 101/166	7,5	5,5		3 ~ 400/690			
	ES.06.022	QM 101/166 S							

3 ~ 400 Volts = Trifase-Avviamento diretto Y / Three-phase- Start direct Y

3 ~ 400/690 Volts = Trifase-Avviamento Y/Δ / Three-phase- Starting Y/Δ

P2 = Potenza resa dal motore / Power rated by the motor

Dimensioni di ingombro e pesi - Overall dimensions and weights

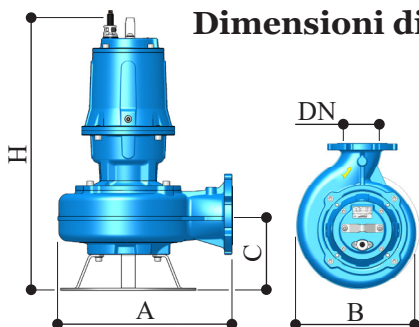

Elettropompa Electric Pump	DN*	H	A	B	C	H ₁	A ₁	B ₁	Kg.
QM 101/165	100	740	450	360	190	860	490	400	96
QM 101/166									103

DN* = PN 10/16-8 fori / PN 10/16-8 holes

La base di appoggio è optional / The foot support is optional

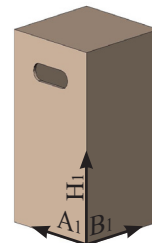

Costruzione - Construction

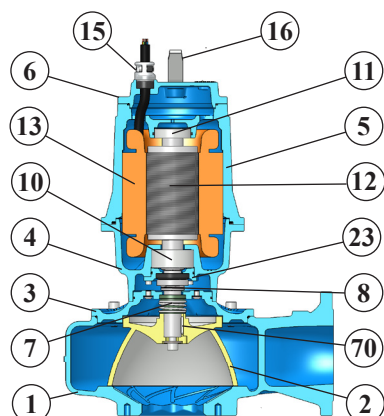

Pos.	Descrizione	Description
1	Corpo pompa GG 25	Pump body GG 25
2	Girante monocanale aperta GG 25	Single channel opened impeller GG 25
3	Flangia tenuta inferiore GG 25	Flange lower mechanical seal GG 25
4	Flangia portacuscinetto GG 25	Flange intermedie GG 25
5	Cassa motore GG 25	Motor casing GG 25
6	Coperchio del motore GG 25	Cover for motor casing GG 25
7	Tenuta meccanica inferiore in carburo di silicio	Mechanical seal on silicon carbide
8	Tenuta meccanica superiore in ceramica/grafite	Upper mechanical seal ceramic/graphite
10	Cuscinetto inferiore	Lower ball bearing
11	Cuscinetto superiore	Upper ball bearing
12	Albero motore AISI 420 + rotore	Rotor + shaft AISI 420
13	Statore	Stator
15	Pressacavo AISI 316	Cable entry nut AISI 316
16	Staffa di aggancio AISI 316	Bracket hook AISI 316
23	Flangia bloccaggio cuscinetto GG 25	Flange bearing blocks GG 25
70	Linguetta	Key

Installazione immersa fissa con dispositivo di accoppiamento rapido codice **RS.28.006 (DN 100)** Permanent submersible version with automatic coupling foot code **RS.28.006 (DN 100)**

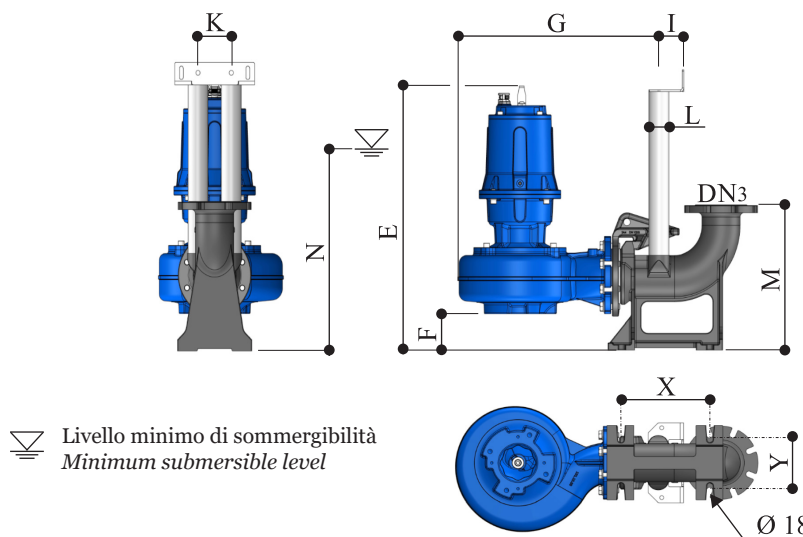
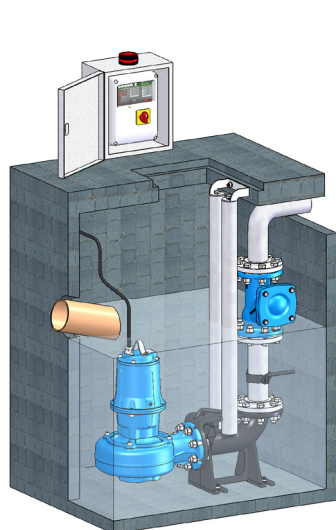

Livello minimo di sommersibilità
Minimum submersible level

	mm
DN3	100
E	727
F	100
G	604
I	75
K	100
L	2"
M	400
N	600
X	265
Y	140

Il costruttore si riserva il diritto di modificare le caratteristiche tecniche senza preavviso.

The manufacturer reserves the right to modify the technical features without previous notice.